

Varenummer: 0109067  
 Beskrivelse: Seeger låsering AS 50X3.0  
 Fjederstål  
 Note: Monteres med ZGA tang

## Mål

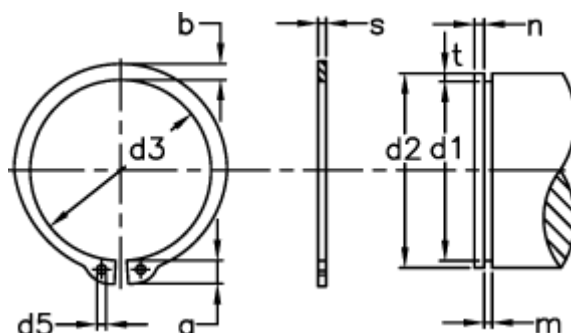

a max	= 8.0	d5 min	= 2.5	s	= 3.00
AN mm <sup>2</sup>	= 229.0	FN kN	= 38.20	t	= 1.50
B	= 2.25	FRg kN	= 32.4	Tang	= ZGA-3
b	= 5.1	FR kN	= 165.0	tol	= -0.08
Betegnelse	= AS 50	g	= 2.0	tol	= +0,39 -0,90
d1	= 47.0	m min	= 3.15	tol	= -0.25
d2	= 50	n abl x 1000	= 11	vægt kg/1000	= 14.80
d3	= 45.8	Nominel træk	= 4.5		